

Product Specification Sheet

LAMERS SANITARY AIR KNIFE

COMPLIANT WITH 3-A SANITARY
STANDARDS FOR CLEANABILITY

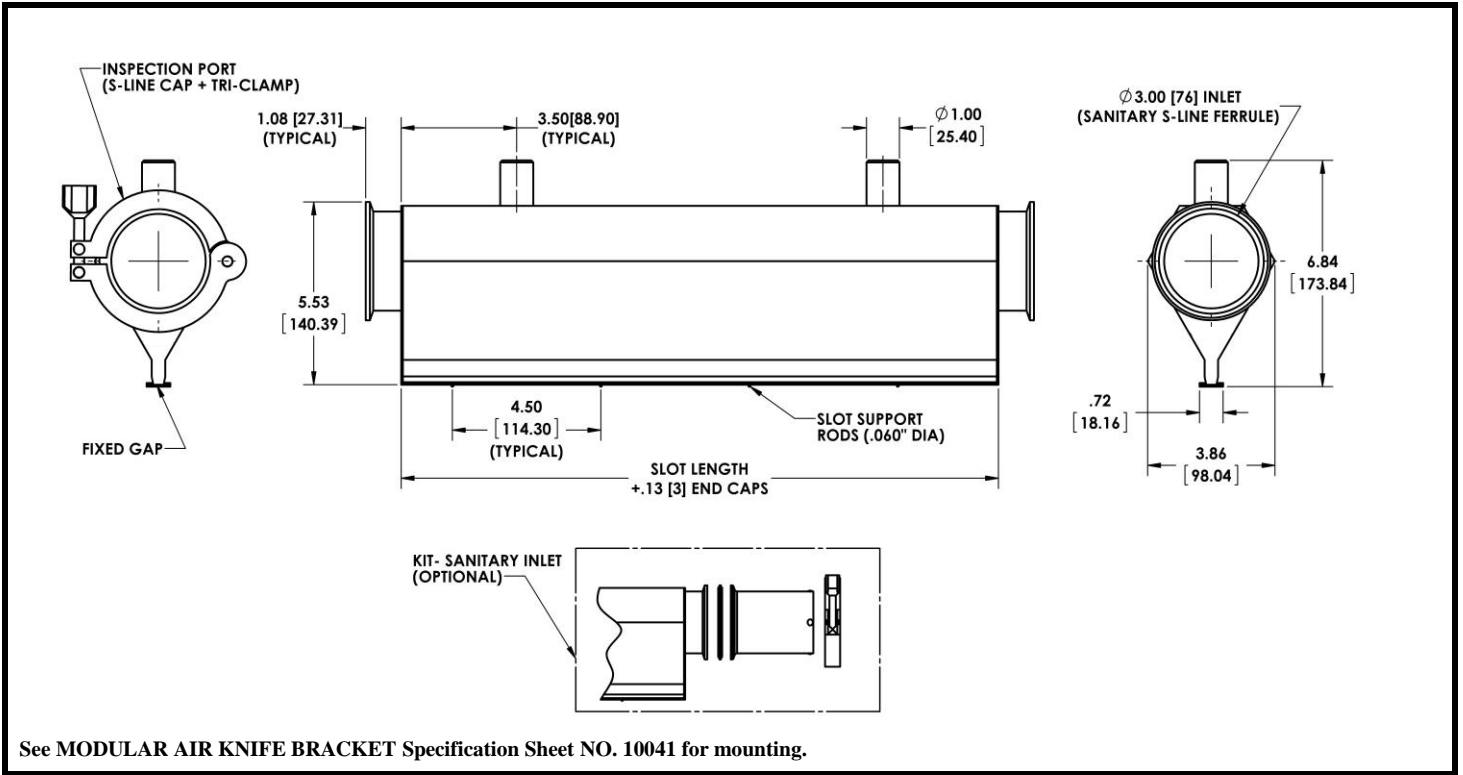

Dimensions in Inches, [] are in millimeters

Description	Air Knife 3" Sanitary	
Part Number	12987	
Standard Slot Lengths	2.0 to 72.0 inch [50,8 to 1828,8 mm]	
Air Flow Rate	3.5 cfm/in to 16.9 cfm/in (65.0 lps/m to 314.0 lps/m)	
Maximum Air Discharge Velocity	38,000 fpm (11,582 mpm)	
Material	Body - 16 Gauge S.S. Inlet/Post - S.S.	
Finish	Electropolish	
Kit-Sanitary Inlet (Includes: Ferrule Tube, Gasket & Tri-Clamp)	P/N - 17018 (4 inch [101,6 mm] L Ferrule)	P/N - 17019 (1 inch [25,4 mm] L Ferrule)
Weight (Approx.)	2.75 lbs/ft (4.09 g/mm)	